

# Syllabus

---

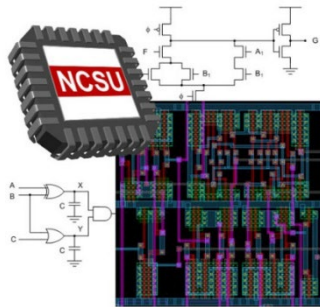

**ECE546-001,-601 VLSI Systems Design**

**Spring 2025**

**Dept. of Electrical and Computer Engineering  
North Carolina State University**

**8:30-9:45am Tue, Thu in 2124 EB3**

## **Instructor**

Professor W. Rhett Davis, 442 MRC, 919-515-5857 (rhett\_davis@ncsu.edu)

Office hours: Tuesday 2-3pm, Thursday, 10:00-11:00am

Zoom Meeting ID: 960 3152 2188, Passcode: mosfet

<https://ncsu.zoom.us/j/96031522188?pwd=U21tQ05FRTRVoVkNEMmIrNVVPWGZ2QT09>

## **Teaching Assistant**

Jeevith Gowda ([jshival@ncsu.edu](mailto:jshival@ncsu.edu))

Office hours: Tuesday 3:00-4:15pm and Thursday 11:00am-12:15pm in EB2 1014

Zoom Meeting ID: 643 117 4974, Passcode: 1912201010

<https://ncsu.zoom.us/j/6431174974?pwd=urWIT1aW97M5mYyCEMGNEMpzoFqJLK.1>

## **Prerequisites**

Completion of ECE 302 (Microelectronics) or an equivalent is required in order to register for this course. This requirement assumes that students have a basic knowledge of BJT and MOS field-effect transistors, IV characteristics, circuit models, SPICE analysis (including basic UNIX commands), single-stage transistor amplifiers (single-ended and differential-pair), calculations of small signal voltage gain, input resistance and output resistance. Students not fulfilling this requirement may register with the permission of the instructor.

## Course Objectives

By the end of this course, you should be able to do the following:

- Create transistor-level circuit-schematics and mask-layout for digital integrated circuits.
- Analyze these circuits with hand calculations to predict their performance in terms of delay, area, and power dissipation.
- Optimize the performance of a circuit.
- Design circuits in a variety of different logic families: Static CMOS, Dynamic CMOS, Ratioed Logic.
- Design complex systems containing a variety of blocks: random logic, integer arithmetic, and memories.
- Analyze the first-order effects of complex and emerging trends in VLSI technology, including crosstalk and variability
- Use state-of-the art computer-aided design (CAD) tools to layout, simulate and verify your circuits.
- Work in diverse teams on a complex project.

## Textbooks

[DigIC] *Digital Integrated Circuits: A Design Perspective*, 2nd Edition by Rabaey, Chandrakasan, and Nikolic, Prentice Hall, 2003.

[LPDE] *Low Power Design Essentials* by Jan Rabaey, Springer, 2009, Available Online at <https://catalog.lib.ncsu.edu/catalog/NCSU2379378>

other recommended texts: *CMOS VLSI Design: A Circuits and Systems Perspective*, 3rd Edition by Weste and Harris, Addison Wesley, 2005.

## Course Requirements

**Flipped Lecture Format:** A "flipped lecture" format will be occasionally used for this class in order to make more class-time available for problem-solving and in-depth discussions. For each lecture that uses this format, students will be required to watch a video module and complete a short online quiz before attending the lecture. Quizzes will be due at 8:30am on the day that its associated video is assigned.

**Examinations:** There will be one 75 minute in-class exam and a final exam.

**Missed Examinations:** If you miss an exam without a certified medical excuse or prior instructor approval, a zero will be averaged into your grade. If you do miss an examination for medical reasons, please give me the contact information for your healthcare provider and give your provider sufficient authorization for me to discuss the reason for your absence. Students attending the NCSU Student Health Center can do that by submitting the Authorization to Release Protected Health Information

(PHI) form found at

(<https://drive.google.com/file/d/1c4I5Rln8gkiACmepuaomtk3J4qmFF9Ah/view?usp=sharing>). Use my contact information (<http://www.ece.ncsu.edu/people/wdavis>) and specify a missed examination as the purpose of the disclosure.

**Homework:** Homework assignments will be issued throughout the semester (approximately one per week). All homework will be submitted online using the “Submit and Grade” link next to each assignment in Moodle. When required to show your work, please submit a PDF file or a scanned image with the problem worked out in order with all of the steps shown. Do not include your name in the PDF file or scanned image. These assignments must represent your own work. Giving or receiving assistance on assignments is allowed, but you may not share any paper and/or electronic material (source code, data files, reports, charts, photos, screen-shots, etc.). Copying of material submitted as part of assignments is not allowed, and there will be no tolerance for cheating. If unusual similarities are noted, a report of academic integrity violation (RAIV) report will be filed. See the Resources for Students at the NCSU Office of Student Conduct (<http://studentconduct.dasa.ncsu.edu/students>) for details.

**Late Homework:** Homework will be due at 11:59pm on the due date posted on the course web-site. Homework turned in late will not be accepted. Because of this strict policy, the lowest homework grade will be dropped.

**Peer Grading:** Because this course teaches design, which is a creative process, it is important that students get feedback on their creativity, which cannot be automatically graded. Due to the limited TA/grader support, peer grading is the best alternative to provide this feedback. For each homework assignment, you will be responsible for grading your own submission plus up to three other students’ submissions, using the same “Submit and Grade” link in Moodle. To ensure fairness, this process will be “double blind”. To ensure “double blindness”, please do not include your name in the PDF file or scanned image when preparing your own submission. The grade you receive for the assignment will be an average of the assessments you receive. Assessments will be due 1 week after the homework deadline, and late assessments will not be accepted. Please contact the instructor or TA if you have difficulty grading or if you feel that an assignment has been copied.

**Assessment Grades:** For each homework assignment, you will receive an “Assessment Grade” that is automatically assigned, depending on how far your homework assessments deviated from the average assessment. This assessment grade may be overridden if the instructor feels that the grader neglected to grade the assignment properly. One criterion for “proper grading” is to leave feedback when deducting points.

**Project:** Students must complete a design project that demonstrates the ideas presented in this class. The requirements for this project will be clarified as the semester progresses. The duration of the project will be approximately the last 6 weeks of class. Students must organize themselves into groups of 3. A significant part of your grade will depend on the performance of your design relative to other groups as well as an assessment of your performance by your group members. The final report will be due on the last day of class, and demonstrations will be arranged the last week of class.

## Online Resources

- **Main Course Web-Page** (<https://moodle-courses2425.wolfware.ncsu.edu/course/view.php?id=8199>)
- **Course Workspace** - 1 GB for each student will be allocated, accessible through the path /mnt/coe/workspace/ece/ece546-spr24/[UnityID]. It is highly recommended that you use this space for completing all assignments, because it allows the instructor and teaching assistants easy access to your files to help with debugging. Otherwise, this space can be used however you like, but it will disappear at the end of the semester. Archiving your storage in this space during exam week is also highly recommended.
- **Video Lectures** – A recording of each lecture session will be available shortly after it meets. These recordings can be accessed with a link next to each lecture's slides on the course web page.
- **Discussion Forums** - available through the "Forums" link on the main course web-page. Different forums will be created for specific topics, but students may always post to the "General" forum. The instructor and teaching assistants will answer questions posted to these forums as well as with e-mail, but preferential treatment will be given to forum posts. Students are encouraged to answer questions as well. It is suggested that postings regarding tool-errors refer to a specific log file and run-directory in this workspace.
- **Online Grade Book** – Grades will be made available online. Details will be discussed in class.
- **CAD Tutorials and help-files** – available at <https://eda.ncsu.edu/tutorials/custom-digital/>. Students will be expected to work through tutorials as part of the homework assignments. Additional resources will be available in the *Design Resources* section of the course web-page.
- **Anonymous Feedback** – may be made using the anonymous feedback form on the course web-page. It is implemented as a Google form but does not log e-mail addresses or any identifying information. Do not be alarmed if you are prompted for credentials. The result will be the same whether you provide credentials or not.

## Grading Policy

### Your grade will be based upon:

- one midterm exam (20%)
- final exam (20%)
- module quizzes (2%)
- homework (18%) broken down as follows:
  - Average of Peer Grades (16%)
  - Assessment Grade (2%)
- project (40%) broken down as follows:
  - Correctness of Milestone #1 (2%)
  - Correctness of Milestone #2 (3%)
  - Correct Operation of Final Design (10%)
  - Physical Verification of Final Design (5%)
  - Documentation (Final Report) (10%)
  - Performance (5%)
  - Partner Assessment (5%)

**Grading Scale:** All assignments will be graded on a 100-point scale. The average of these assignments (using the weights above) will be used to compute your final score. The following scale will then be used to assign your final grade:

100-97	A+	97-93	A	93-90	A-
90-85	B+	85-80	B	80-75	B-
75-70	C+	70-65	C	65-60	C-
60-40	D				
<40	F				

**Gray Areas Between Guaranteed Letter Grades:** There will be a gray area of several points below the specified numerical cutoff grades. Two people getting the same weighted average (say, 89) might therefore get different course grades (A- and B+). If you are in one of those gray areas, whether you get the higher or lower grade depends on whether your performance on homework has been improving (it goes up) or declining (it goes down) and whether or not your attendance in class and office hours has been frequent (up) or infrequent (down).

**Audit Requirements:** Students auditing this course are expected to complete the homework assignments and peer grading with at least a C- average (above 60). Module quizzes, Exams, and the Project may be omitted.

## Academic Integrity

All assignments must represent individual effort (i.e. your own work). Giving or receiving assistance on assignments is allowed, but you may not share any paper and/or electronic material (source code, data files, reports, charts, photos, screen-shots, etc.). Offering or receiving these materials is not allowed, and there will be no tolerance for assignments that show signs of sharing these materials. If unusual similarities are noted, an academic integrity violation report (<https://studentconduct.dasa.ncsu.edu/faculty/confronting-academic-misconduct/>) will be filed, which may lead to suspension. See the Resources for Students at the NCSU Office of Student Conduct (<https://studentconduct.dasa.ncsu.edu/students/>) for details.

## Supporting Fellow Students in Distress

Academic life is often more stressful than we would like. Everyone is encouraged to [take care of themselves](#) and their peers. If you need additional support, there are many resources on campus to help you:

- Counseling Center (<https://counseling.dasa.ncsu.edu/>)
- Health Center (<https://healthypack.dasa.ncsu.edu/>)
- If the personal behavior of a classmate concerns or worries you, either for the classmate's well-being or yours, we encourage you to report this behavior to the NC State CARES team:  
([https://cm.maxient.com/reportingform.php?NCStateUniv&layout\\_id=2](https://cm.maxient.com/reportingform.php?NCStateUniv&layout_id=2))  
Although you can report anonymously, it is preferred that you share your contact information so they can follow-up with you personally.
- If you or someone you know are experiencing food, housing or financial insecurity, please see the Pack Essentials Program (<https://dasa.ncsu.edu/pack-essentials/>).

## Accommodations for Disabilities

Reasonable accommodations will be made for students with verifiable disabilities. In order to take advantage of available accommodations, students must register with Disability Resource Office (919-515-7653). See <http://dro.dasa.ncsu.edu> for details.

## Changes to Syllabus

Any additions or modifications will be posted to the web-page and announced during lecture.